

D13-2075

ISSUE
F

FIRST W.O.

IF IN DOUBT-ASK
DO NOT SCALE

		DIMENSIONS	
		FRAME	"A" "B"
4-POLE	164 A	376,5	105
	164 B	376,5	105
	164 C	403,5	119
	164 D	403,5	119
2-POLE	162 D	376,5	105
	162 E	376,5	105
	162 F	428,5	144
	162 G	428,5	144

COUPLING DISC					
SAE	"AN"	"AM"	"AP"	"AR"	"V"
8	61,90	6	10,3	244,5	263,4
10	53,98	8	11	295,3	314,2
11,5	39,68	8	11	333,4	352,3

*2-DISC COUPLING
FOR SAE 11,5 ONLY

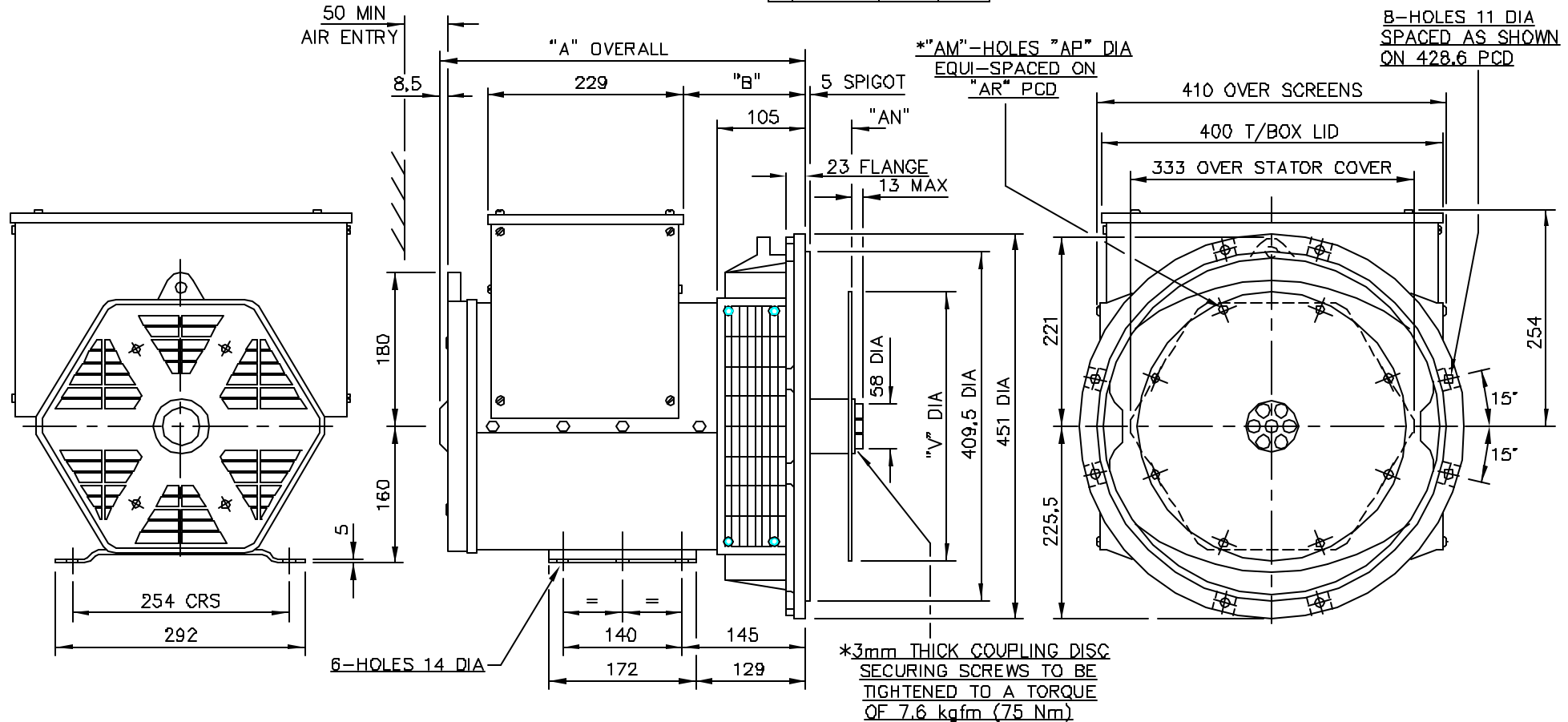

4/2427/4	F	JWS	12.8.99	*AP" DIMN Ø11 WAS Ø10,3 IN TABLE FOR SAE 8 COUPLING DISC
4/2427/2	E	JWS	27.6.99	*AP" DIMN Ø11 WAS Ø10,3 IN TABLE FOR SAE 10 & 11,5 COUPLING DISCS
4/1181/1	D	A.J.B.	25.11.98	23 FLANGE THICKNESS WAS 14.
4/0789/3	C	M.L.W.	12.8.96	PREVIOUS ISSUE STATED D MOD (TYPING ERROR)
4/0789/2	B	M.L.W.	11.7.96	NOTE:- 2-DISC COUPLING FOR SAE 11,5 ONLY ADDED.
4/0083/1	A	A.S.	16.6.95	ORIGINAL ISSUE
MOD	ISSUE	DRAWN	DATE	ALTERATION

CERTIFIED PRINT		
(ONLY IF SIGNED)		
BY		
DATE		
DRAWN	A.S.	16.6.95
CHECKED		
APPROVED		

BC162/164
1-BEARING ALTERNATOR
SAE 3 ADAPTOR (1PIECE)
SAE 8, 10 & 11,5 COUPLINGS
NEWAGE INTERNATIONAL LTD
STAMFORD ENGLAND

SCALE	FIRST W.O.
1:5	
D13-2075	ISSUE F